

excerpt of
Material
Reviews:
the social
shelf project

by
Gersande
Schellinx

18.06.2023

The social shelf project
in short: sustainable,
economic, 'transparent'
designs. An idealistic
approach to making
considering whether



— small designs made in
contextual situations and
for the local by the local
can create new strategies
for people to bond with
their surroundings

— more empathetical
relationship to objects
can bring social change.

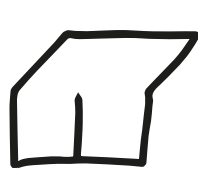
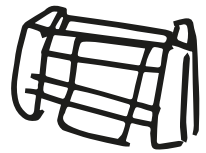

Material
Reviews:
the social
shelf project

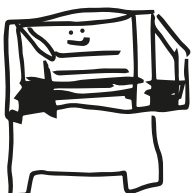
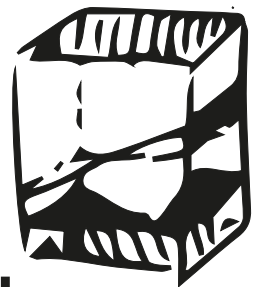

Disclaimer



This is not a work of fiction. The Material Reviews of the social shelves project are a personal recounting of my experience prototyping and building 'social shelves' between 2022 and 2023.

Names and other details have been changed to protect the privacy of certain organisations and individuals. The political beliefs, social dynamics, moral and economic values of the different contexts for which those objects have been produced vary. As to not melt those different layers into one, some contexts will be reduced in our text to an abstraction of their spaces.

Circumstances have led me to produce objects for those different places. Some places I have been invited in, others, I have offered my help, or am familiar with. These different locations illustrate the variety of material needs that emerge in different contexts. The diversity in networks created an opportunity to illustrate how the necessity for small designs is omnipresent, even if it varies in form and urgency. My attempt to facilitate encounters bringing people and objects together has allowed me to better grasp the implications of different material narratives. It has been a humbling and exciting experience altogether.

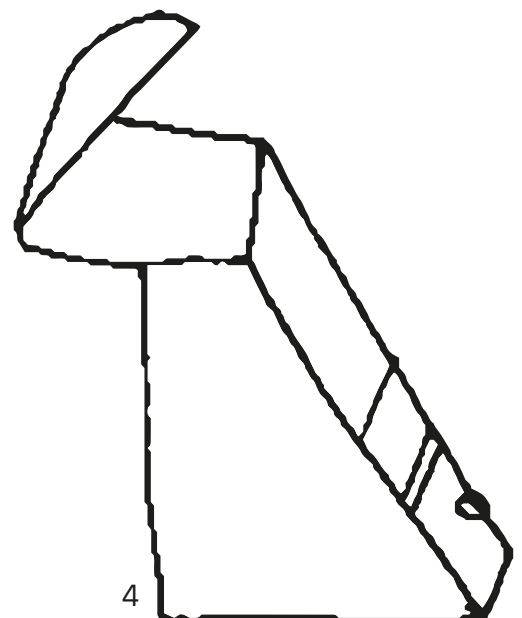
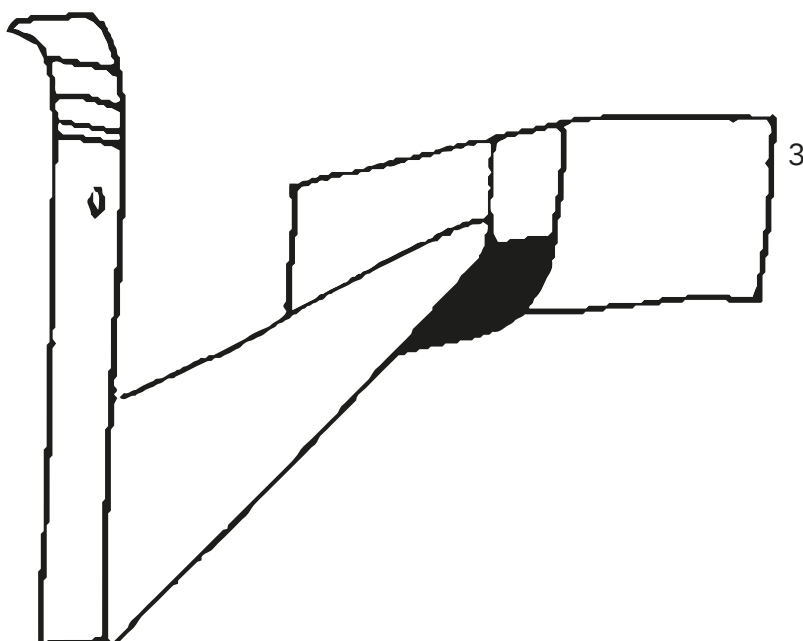
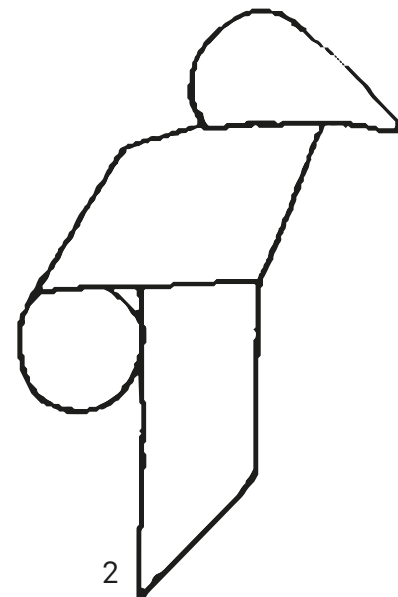
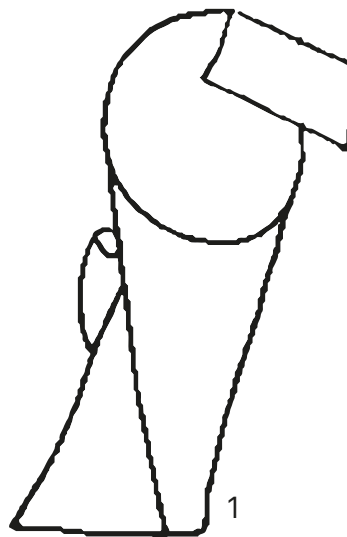

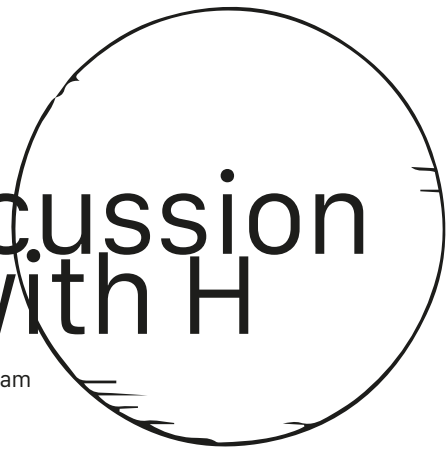

Discussion with H

Location: Amsterdam
01.06.2023

G: I've been working on something called the social shelves project.

It started with an object given by my mother years ago, an old antique book support/end. I've been calling a shelf, because you can travel with it, unfold it in any location so that you always have a bookshelf with you.

I wanted to focus on that one object in the context of my master. The hosting space, the small scale of the object that allowed for more experiments and prototyping. I thought 'let's call it "social shelves"', to cover every possible type of shelf: 'book support, bookends, bookshelf, case...' anything related to this and not limited to books. I wanted to really focus on the object, without a priori limiting what should go on it.

I decided to build five different social shelves. Ultimately, my fantasy around the project was 'how do we make small designs more accessible to create more custom-made but still sustainable and affordable objects'. Ideally, I would have gone to different places and help people make these objects for themselves; me, acting as a facilitator, rather than a designer-author.

Because of the time restrictions and the need to do more research on these topics, I decided to cut the workshop aspect for now. Instead, I searched for places in different contexts in need of shelves. The shelves that come out of this are all to me prototypes of what can be. They are not end products.

H: Yeh, always a work in progress.

G: Yeh case studies for these contexts. Can we do these small designs? The idea is that also if you can understand how

they are made, you can also repair them easily or reproduce or... You don't have this helplessness that a lot of people have with the objects around them that if something breaks it becomes obsolete. Their premature obsolescence creates a lot of waste.

The last one which is not published yet... Oh yes, I started to think about the moment I let the shelves be in their context as a publishing moment. I haven't 'published' P. Enches yet, it is still in my studio.

H: Publishing the shelves!

G: I don't want to display [in the graduation show] these objects that are not in context, because it would turn them into products. So for the show I want to only have the suitcase on display. I'd rather build new shelves for the show that are in context than bring the other ones out of their context. I'm not gonna build a bench for this object [P. Enches] for example. But what happens to it if I show it without a bench?

How will I make shelves for the show? C said 'oh we have all these scraps'; for me this was very exciting because I'd much rather work from these than make a design that needs a very expensive material base to be obsolete after three days, it's such a waste.

H: Totally, and I also think that, using scrap material gives it an ongoing life and I think that's really nice. How do you do something with cheap materials and also accessible building methods, the process of building together and all that kind of stuff...

where are the social shelves?

29.06.2023

As my studies come to an end, etiquette wants me, as a student, to display both my research and the works I have produced in that period of time. In June of 2023 an exhibition will take place at WOW in Rotterdam. Eleven artists and designers, including myself, are graduating from the Experimental Publishing (XPUB) master. Time to shine: this is our graduation show.

But, the objects in this publication live in another space. One that does not belong to the space you are currently in. You do not need these specific objects to be in front of you to reflect on them. If this publication reaches you after this 'show moment', you should know that most of the social shelves weren't exhibited on the occasion.

Where are the social shelves?

Despite this being a much anticipated moment to exhibit my 'skills' to the public, I decide a few months before the show that I won't present, physically, most of the objects I have built in these past six months.

Why this resistance to show what most would consider as my designs? There is this reluctance on my part to be considered as designer-author. I consider my real achievement of this experience to be the process that led me to conceive those objects rather than what most would consider as the 'end-products' themselves. I want to position myself as a mediator and facilitator, not as designer-author. To present those objects as supposedly 'end-products' would put a premature end to this inquiry. Yet it is not over and will continue after my graduation.

In this context, the thought process of how to conceive something supersedes the item itself, that is what has been made. I want to invite others to participate in this experience to find ways to create more adaptable and more sustainable approaches to design. So what could be better to circulate this project than turning it into a publication?

A temporary exhibition space is an unsustainable space. It displays what you want others to see, but only for a limited time. It shows but it does not keep showing after a certain date.

The social shelves built for this project have already been 'facilitated' into their dedicated spaces. It felt contradictory to the aim of this project to tear them away from their publication space just to display them temporarily in one where they have no real use. The briefness of a graduation show does not align with the philosophy behind the social shelf project that wants to live on and adapt in various spaces, not of display but of actual use. This refusal of exhibit my work is therefore not meant to challenge the legitimacy of exhibition spaces.

In my previous education, I produced a lot of things for hypothetical or fictional spaces, performative artefacts that didn't respond to any real-world needs. Made in unrealistic circumstances, they were unsustainable, unaccessible, unreproducible and unaffordable. The social shelves project challenges these issues resulting from a deep contradiction between, heavy production, for too short activation time.¹

I also want to question design authorship. When do I own a design? Or an object? All the shelves I have built were meant to answer specific needs, instructions or time, space, and material restrictions in relation to the context and use of shelves.²

I did make some technical and material choices to translate those needs. I sampled already existing designs, re-appropriated

features found in existing objects and adapted to the materials available in those contexts. As such, I consider myself to facilitate the becoming of these objects, rather than owning them or claiming authorship over them.

Instead of defining myself as the designer-author I have trained to become, I have chose to take on the role of a mediator between contexts and objects, a facilitator for materiality to enter in a dialogue with its surroundings. My practice is about engaging with the need of a place, putting accessibility and sustainability at its core, not superfluous performativity. It considers how we can create an empathetical bond with our environment through small designs? A material kinship of some sort, uniting people and objects.

The social shelves are already where they ought to be. They have espoused the context for which they were conceived. This, to me, is their true achievement.

¹ Time spent planning, producing and making something. Financial investment unrealistic on larger scale or in an economic exchange. Unpaid labour. Unreproducible designs... I don't take pleasure from the contemplation of a completed project. I take pleasure in its long-term activation, which is when I see it come to life through another's eyes. Projects should be a communal experience not a singular one.

² Take my work as a book binding workshop manager at the Gerrit Rietveld Academie. Students come to me with projects that are more or less prototyped or conceptualised. My work is to help them translate their ideas into a material platform I understand the language of. Do I consider myself an author of those projects? Do I own any of those prototypes? No, I have facilitated the encounter between a person and an object.

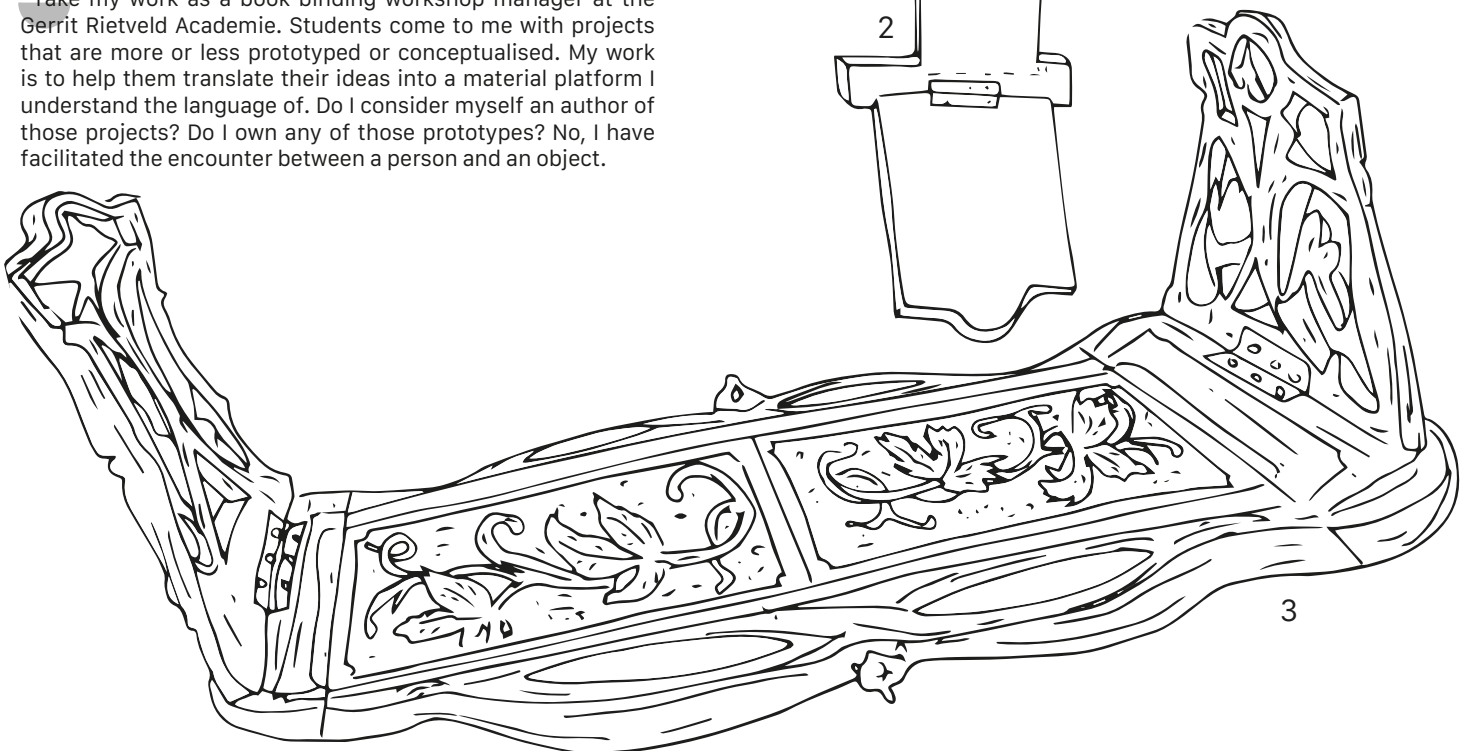
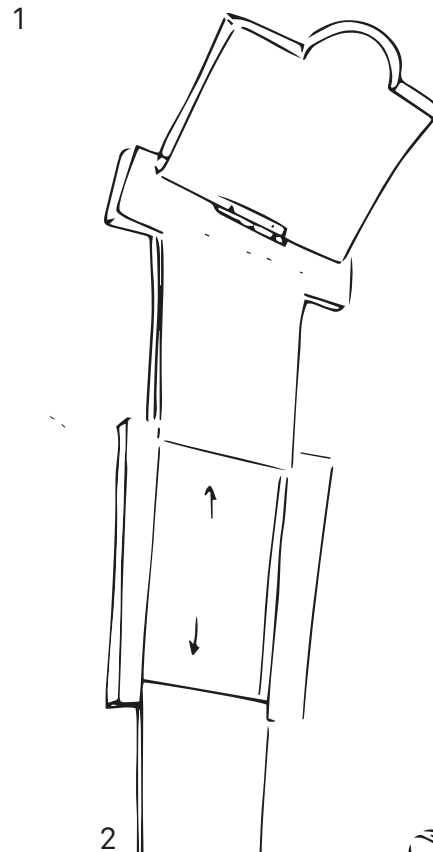
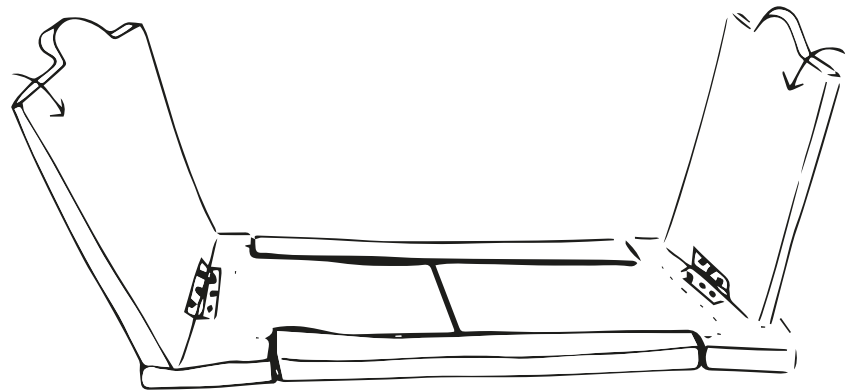

A 'seamless' design

Location: Rotterdam
Name: B. Zamp
Publication date: 05.11.2022

The first shelf named B. Zamp (short for 'books zine camp') was made in accordance to this given instruction 'we have a suitcase full of books, from all different sizes, could you make us shelves that would fit all of them and maybe also the suitcase?' (at least that is how I remember it).

November 2022, the Zine Camp in WORM Rotterdam is coming up. M and J turn to me 'wouldn't making the shelf for the XPUB department at the Zine camp be the perfect opportunity to try out your material research?'. And they were right. I had been unsure what would be a good opportunity to put my recent theories into practice.

Immediately, a multitude of possible objects came to my mind. All had at their core, this feeling of a shelf integrated to an already existing suitcase. Strings and knots, ropes and beams, were crossing and folding and weaving into one another in my head, yet nothing seemed to be simple enough or strong enough to resist back and forth transport and allow successive dismantling while also holding all those publications that weighed a significant amount.

Consequently, I started looking into my favourite kind of furniture-object, old carrier-box for cameras, clothes, accessories. A lot of those old artefacts are made out of wood.

Around the same time, we had an event at the Leeszaal in Rotterdam with XPUB, a library for books obviously, but also for shelves. All kinds of shelves blossom/ arise in this incredible space from the ground up to the ceiling. With cheer excitement, I meticulously documented each of these fantastic objects. One of them, located close to the entrance was a simple box, a diagonal line separating it in two halves that when opened turned into an elegant book display.

With those two artefacts in mind (the carrier-box and the Leeszaal box-book-display) it quickly came to my

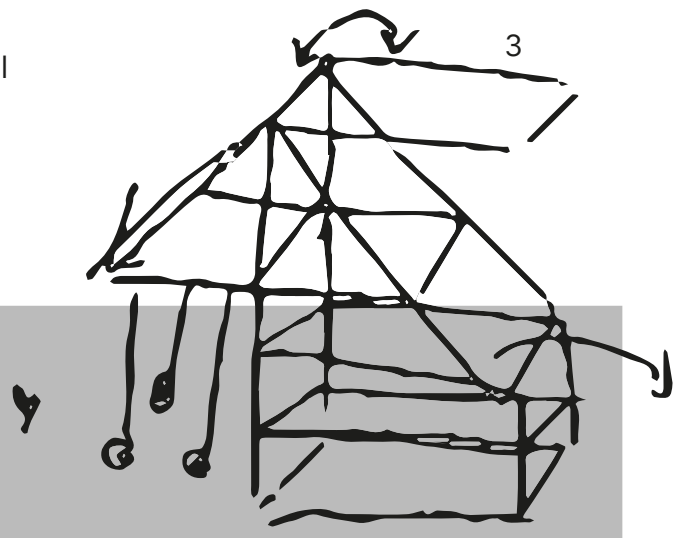
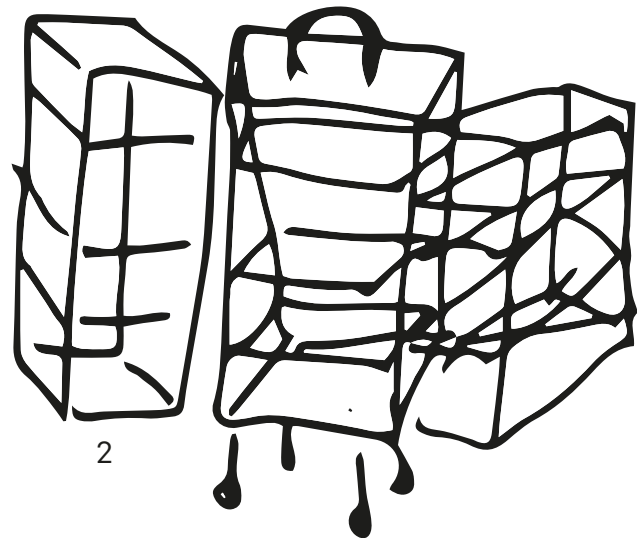
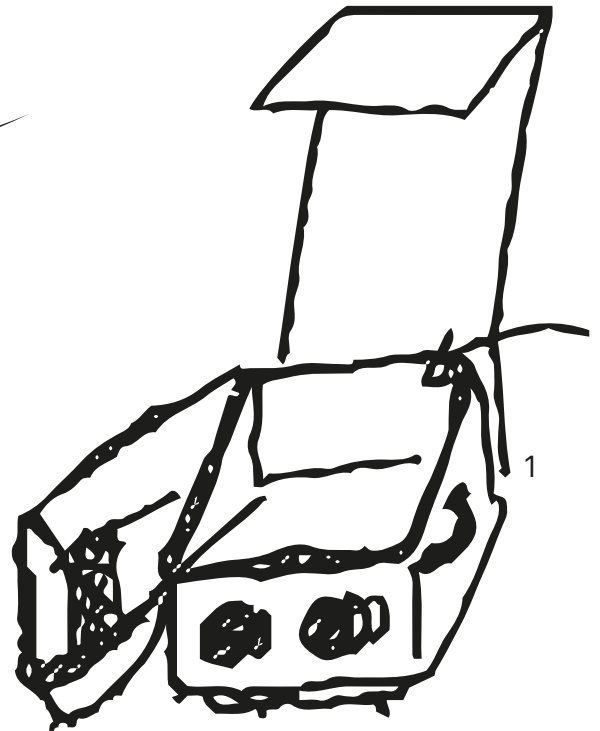

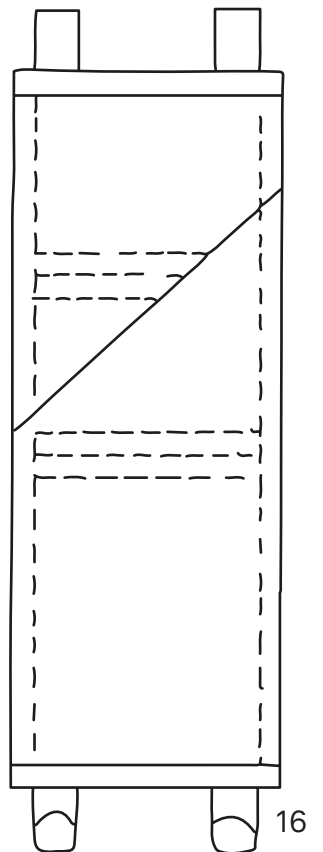
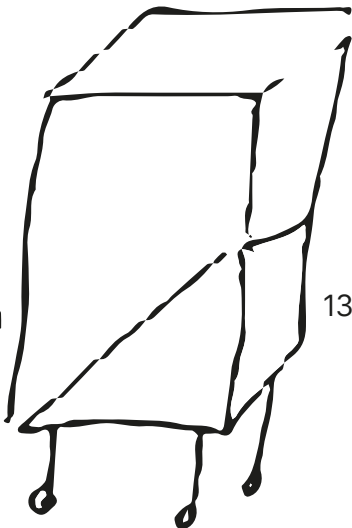
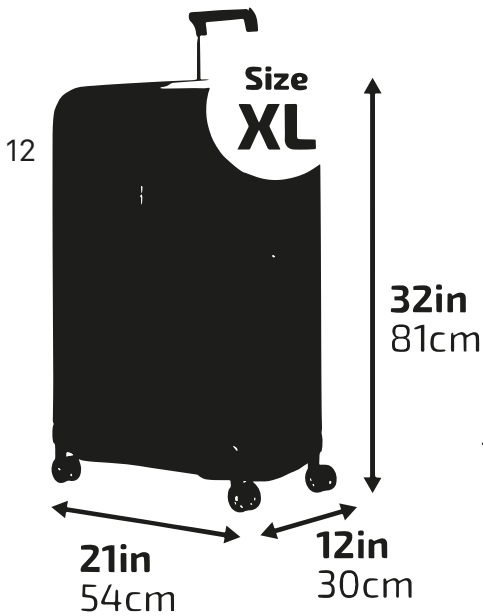
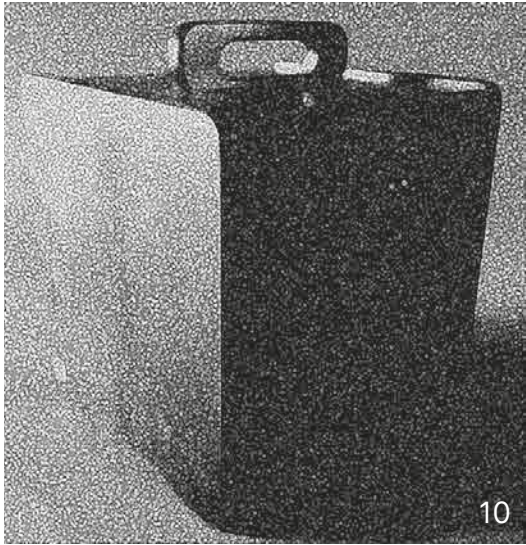

B. ZAMP

1

2

3

15

social shelf 1.
piet zwart institute x gerrit rietveld academie
zinecamp 2022 WORM Rotterdam, not just a fair Arnhem
wood, hinge, screws, wheels, slots
80cm x 50cm x 30cm

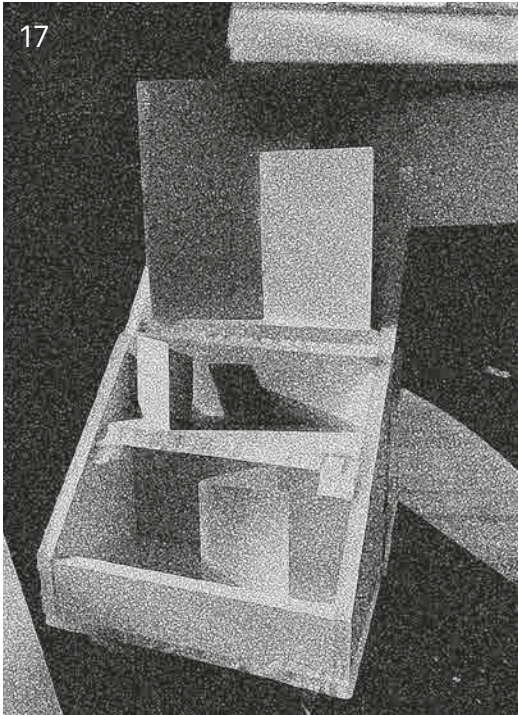

realisation that while I couldn't fit the perfect shelving system in the suitcase I was given, I could instead build the perfect suitcase to display the shelves. I set the dimensions to an XL suitcase size (around 80 × 50 cm), enough to fill it with publications from all size and shapes.

Just wheel it to the Zine Camp, open it and bam: once the planks on the inside are set, you have a book display and the shelves won't move! A door-to-door salesperson's dream!

Hearing this you might think 'Amazing! You did it! Fantastic!', but actually I failed to succeed. My design had become of such complexity in its seemingly seamless simplicity that it could not live up to the basic requirements of a 'social shelf' to be a 'sustainable, economical, transparent contextual design'.

During this first attempt, I dived into Enzo Mari's hammer & nails designs part of his Autoprogettazione? project. I really look up to his accessible and ingenuous designs, that could be altered to the local needs; the importance he gives to method over product, his 'open' designs for every day furniture.

Even though I aspired to create objects of similar simplicity, B. Zamp turned up to become a very complex piece of work. I was given this assignment two weeks before the event. In my rush I unwisely chose to buy new material, including all the accessories necessary to carry it, close it and open it. Which made the cost of the object rise and be more expensive than a simple IKEA BILLY bookshelf!

In order for it to open smoothly, the suitcase needed a lot of cuts in a 45° angle. To make those cuts a lot of heavy expensive machinery was used. These tools and the technical knowledge they require are scarce commodities. The same cuts created challenges to screw in the hinges, made for 90° angles, and necessitated adding an extra space onto the object. Making those 'seamless' cuts came at a high material cost and called for extra-material to be added to the edges of the object.

Without the wheels the two parts are of equal height, once the suitcase opens the wheels add height on the lower part. The wooden handles added to the design were meant to prevent that once opened the suitcase's upper part would float above the ground once opened.



The production of these custom handles to a right size (most industrial handles were not solid enough, too small, too big, too round, etc) turned out to be a very specific and difficult process. The wheels needed to support the heavy load were expensive, and it remains hard to pilot on uneven grounds.

Despite all those issues encountered during manufacture. B. Zamp has proven to be the perfect social shelf in the XPUB context. Since its manufacture it has travelled to several events becoming a satellite space for XPUB publications on the road. It easily hosts publications ranging from <A5 to A2> formats, embracing the constantly shape shifting output of students.

B. Zamp has become a token of the master's entity. Easy to manipulate, it can be set up by anyone in the program. It responds to the needs it was set to meet, but ultimately failed to simplify manufacture protocols and means. Hard to reproduce, B. Zamp does not challenge, but reproduces the problems that arise from investment in heavy production cycles.

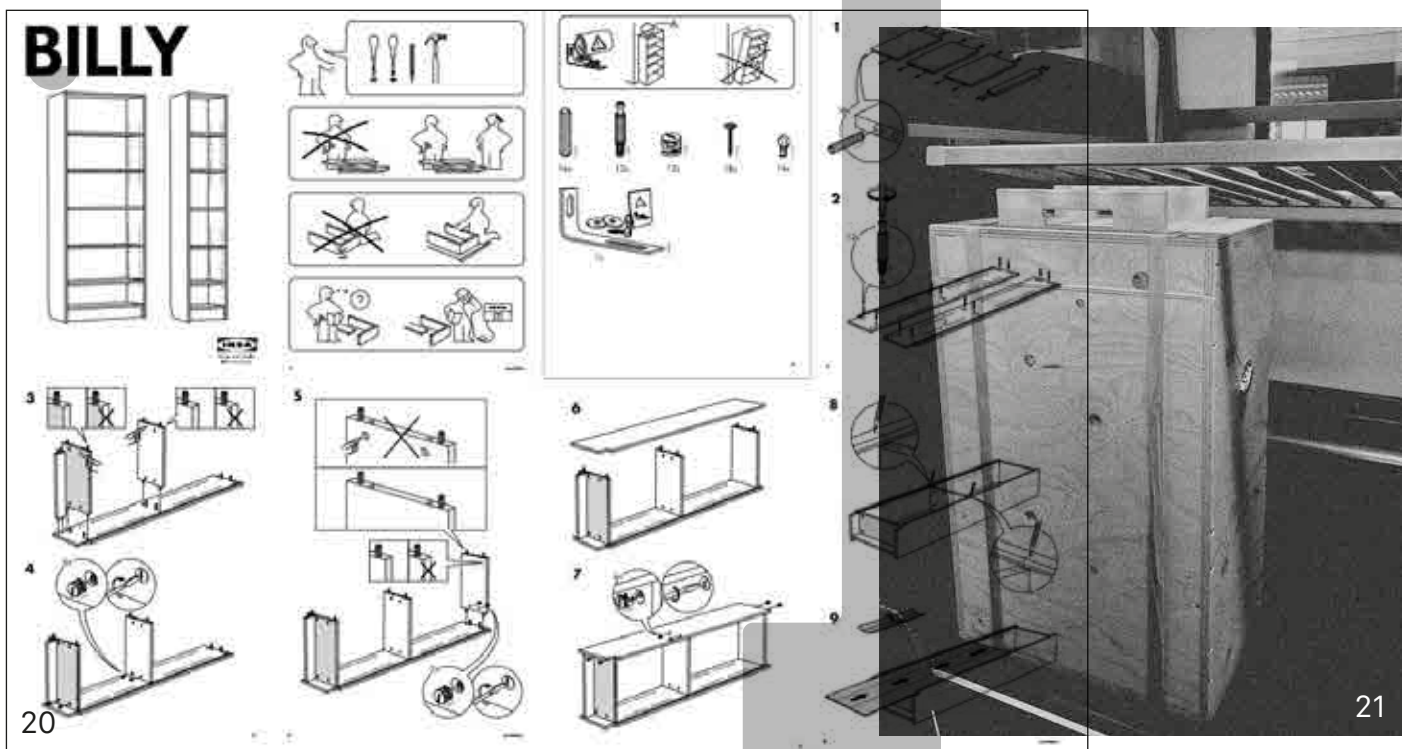
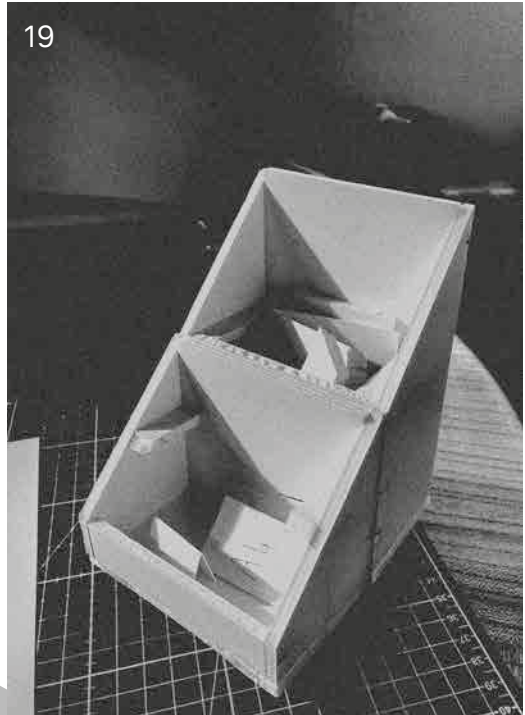

22



23

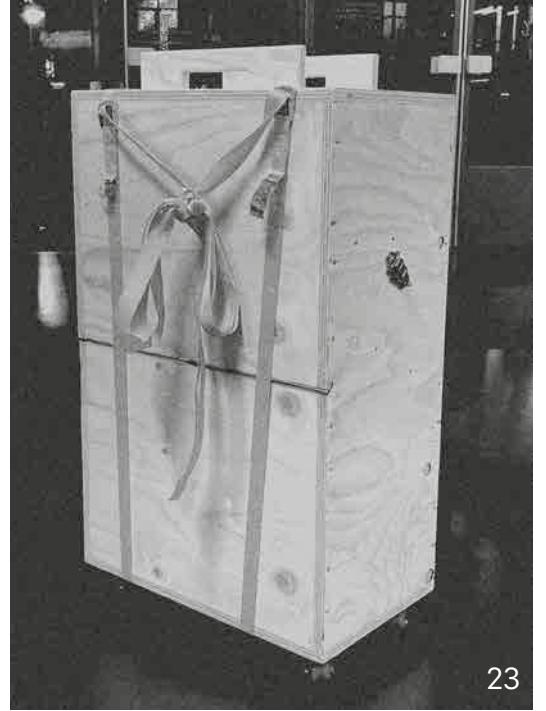

24

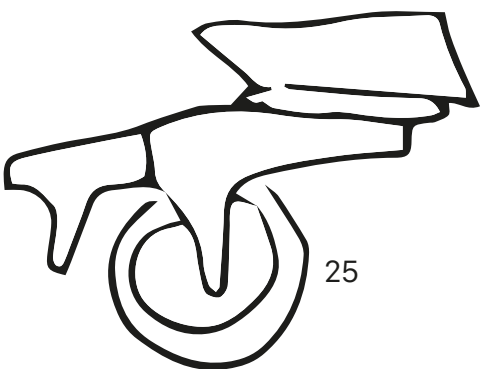
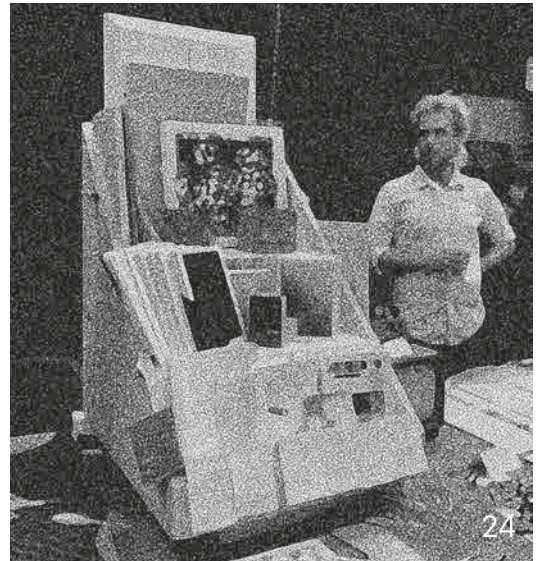

25

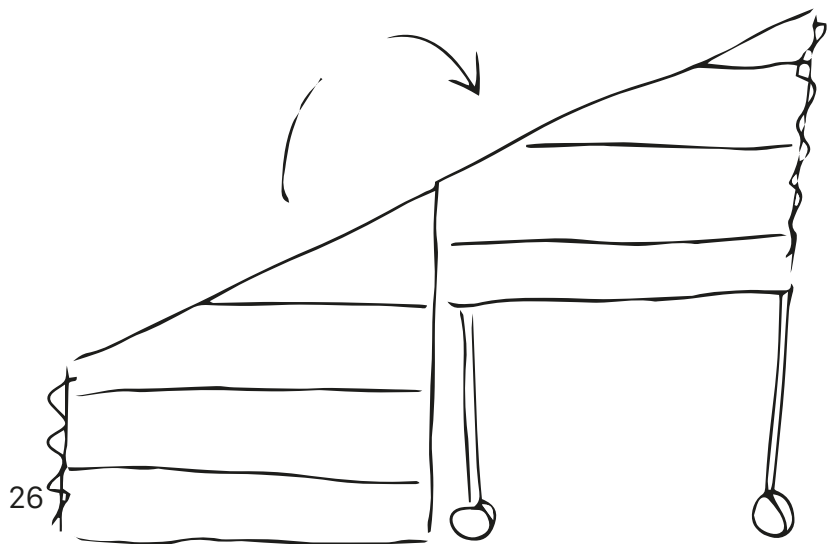

26

420. × 297 times three

Location: Amsterdam
Name: B.B. Wop
Publication date: 10.12.2022

B.B. Wop (short for Book Binding Workshop) was made with very clear restrictions. No screws, no accessories. One flat surface, easily cut, easily assemble, easily stored.

In the mentality of the BB Tools (designed by my colleagues and produced in collaboration with the book binding workshop and other GRA workshops).³ The series of objects made since 2019 are meant for students to learn how to make tools by themselves in a collaborative and playful way. Students take part to the making process and get to reflect on the tools they use, understand them better and get agency over a technique, which they can then proceed to reproduce, alter, or re-imagine.

Students that come by the book binding workshop always carry papers, prints, dummies with them. Yet they don't necessarily have a space to store, gather or display these materials. B.B. Wop was imagined to be the perfect space for these works in progress to be carried around school, shown to teachers, or stored on desks.

Quickly I decided the design of this shelf should fit on an A3 format. A3 is the most widespread paper format (after A4), readily accessible and easy to copy, scan and reproduce. The design of B.B. Wop soon proved to fit on three pieces of A3.

In the following production stage, the cutting, the flat design, proved to be a perfect fit for the laser cutter: the three A3s took just as much as the maximum size available in the laser cutter available for use at the WDKA (800 × 450 mm, coincidentally the same height and width as B. Zamp).⁴ Three A3 turned out to be an optimal size to produce a shelf that has a strong core body and modular pieces that can easily be assembled and taken apart.

If this design is indeed easy to reproduce and manufacture, the few prototypes that I managed to make between November and December have revealed several flaws.

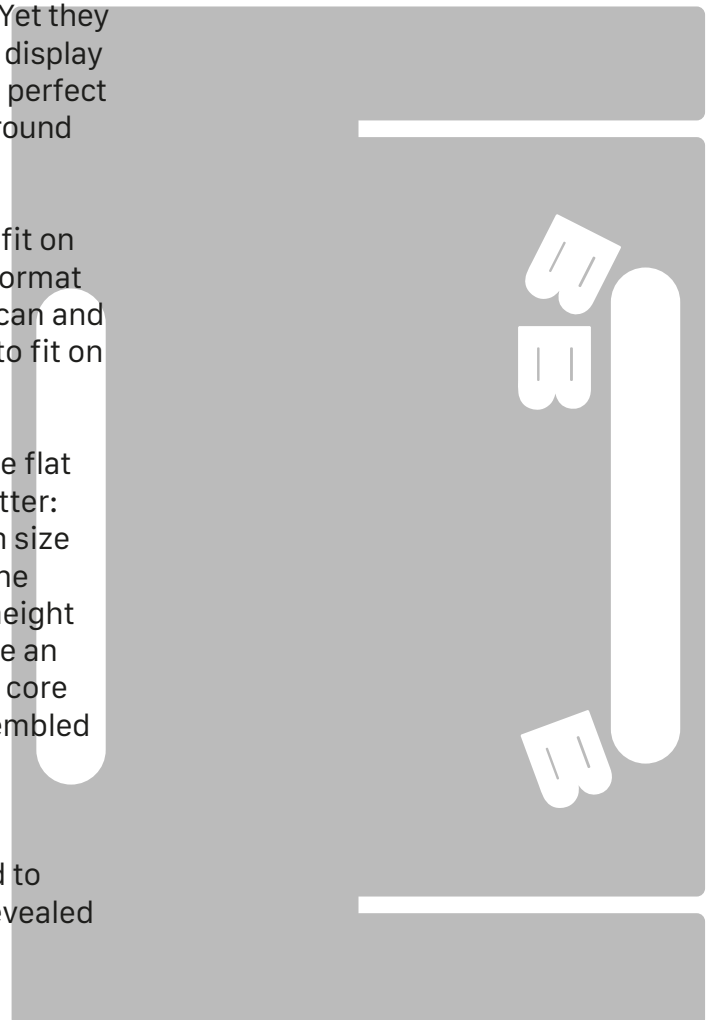
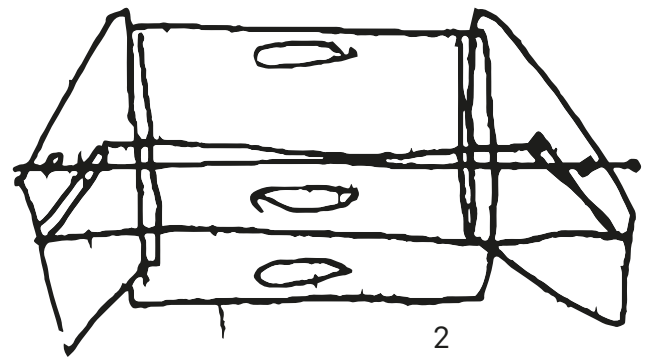
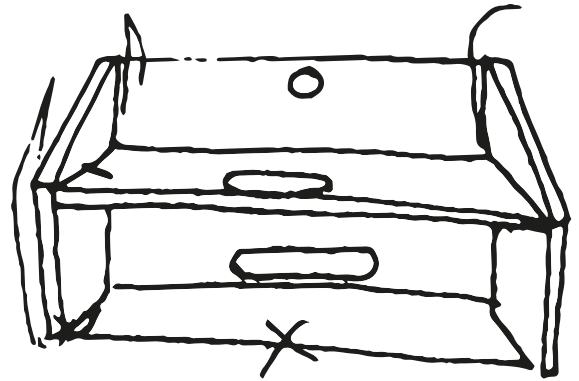

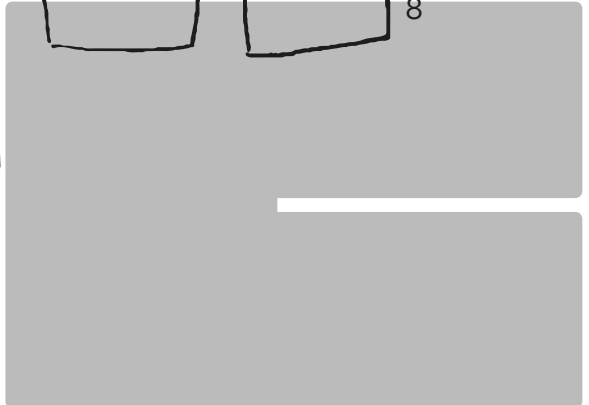
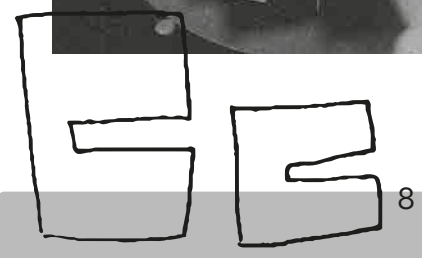
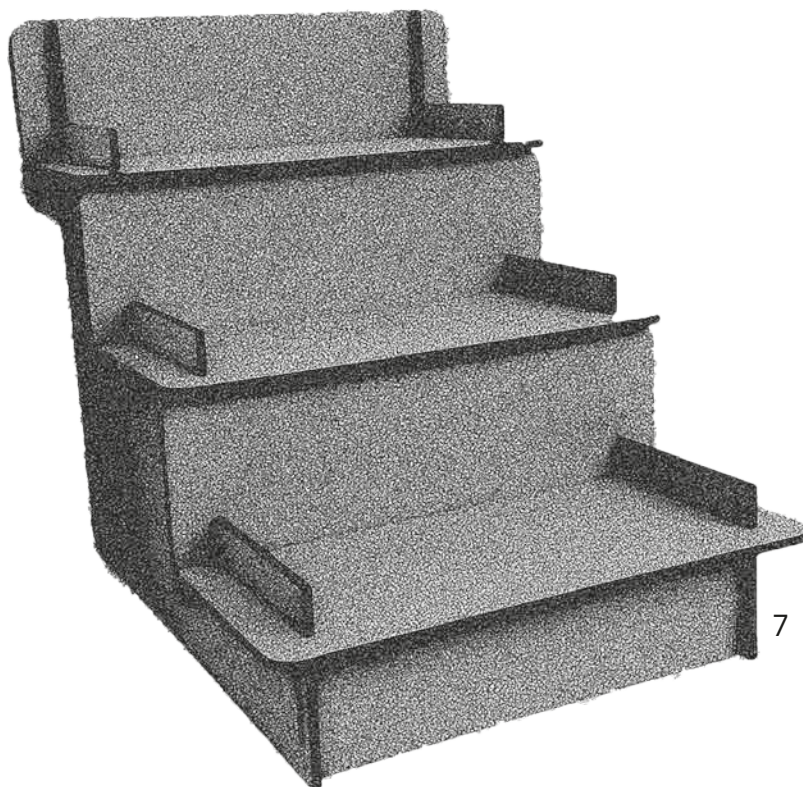
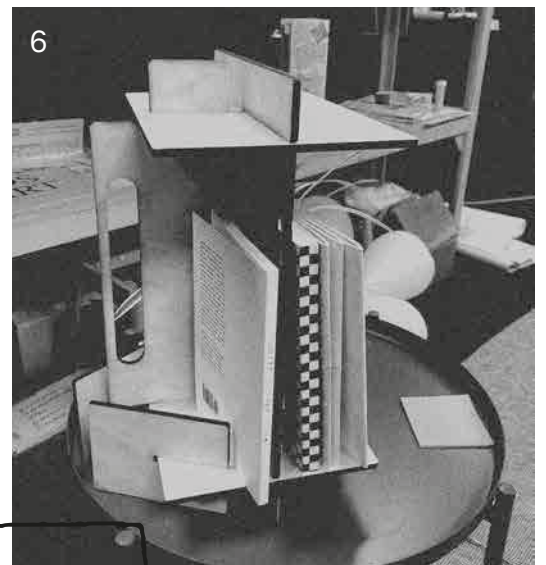
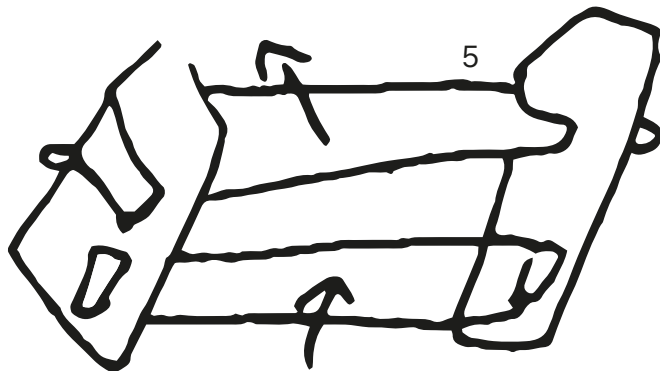
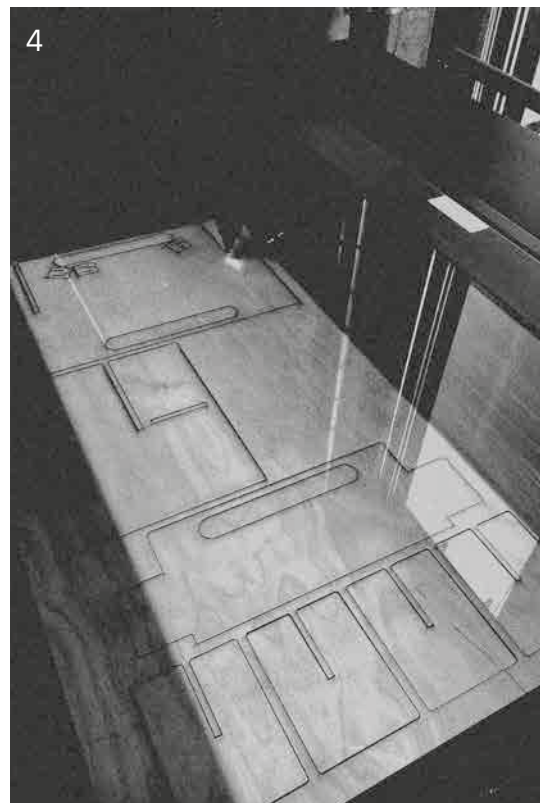
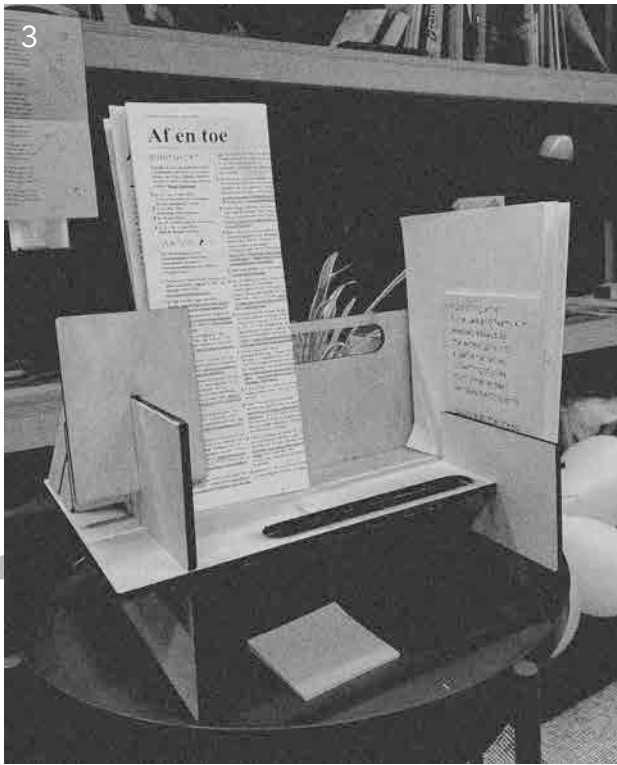

The thickness of the material used cannot be more than 6mm. The first prototype, made in thick birch wood, proved to be much sturdier than the 3mm acrylic, which next to being too light also proved to be slippery. Thus, acrylic materials would need to be thicker (most wooden materials have a natural grip, especially after being cut) or need some kind of extra accessory locking the different parts into places after being assembled. The different modes of assembly of the shelf allow some degree of versatility, but because the design fits on A3 sheets, the range of publications formats that it can fit is necessarily rather limited.

Still the A3 format makes the design itself easy to access and reproduce. It also allows the user-maker to alter the design as they please and customise it to their wants and needs. The production of B.B. Wop is not necessarily limited by access to a laser cutter of the right size. The A3 format allows cuts to be done manually using a saw or any kind of cutting technologies less expensive than the laser cutter.

All in all, low cost equipment and material make the B.B. Wop shelf fitted to the context of the BB tool series meant to involve students.

³ BB is the short and affectionate acronym used to refer to the Book Binding workshop. The BB is my workplace at the GRA, short for Gerrit Rietveld Academie.

⁴ WDKA is short for Willem de Kooning Academie. The XPUB master is located in the same facilities as the WDKA's bachelor programs and uses the same work stations. The laser cutter at the GRA has a maximum size of 800 x 600 cm.

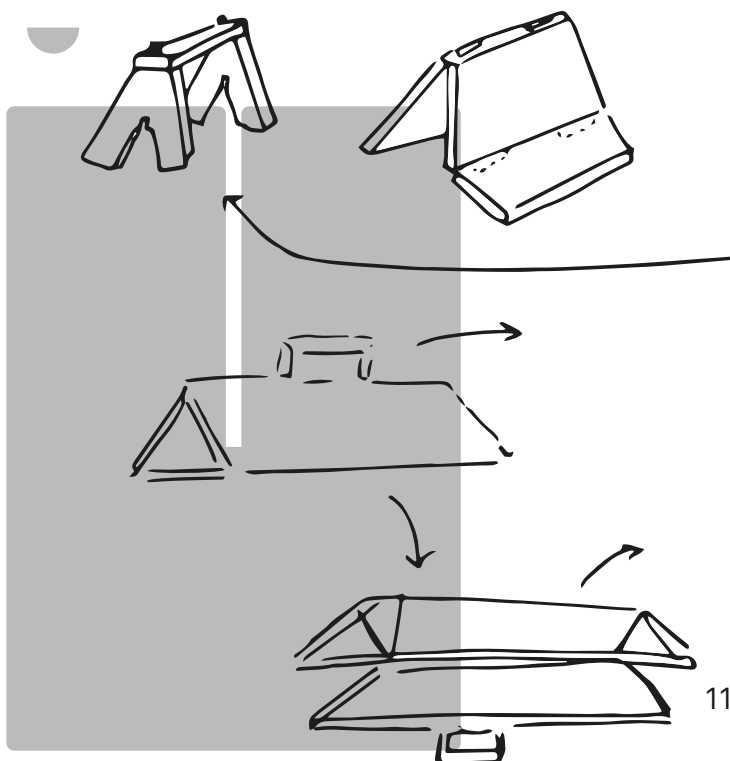
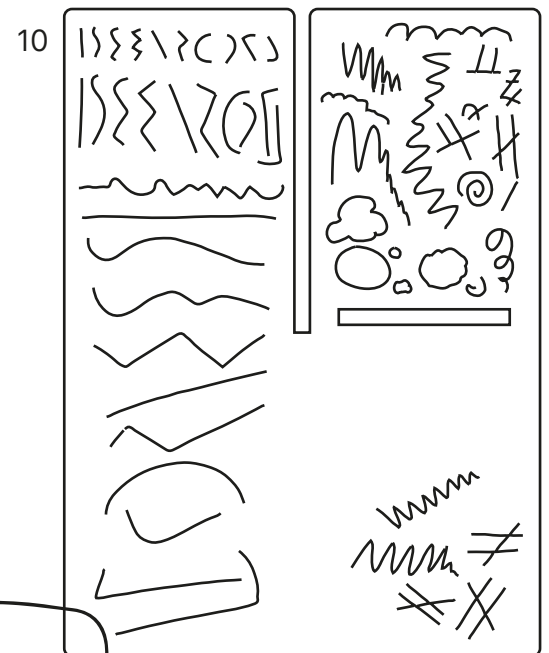
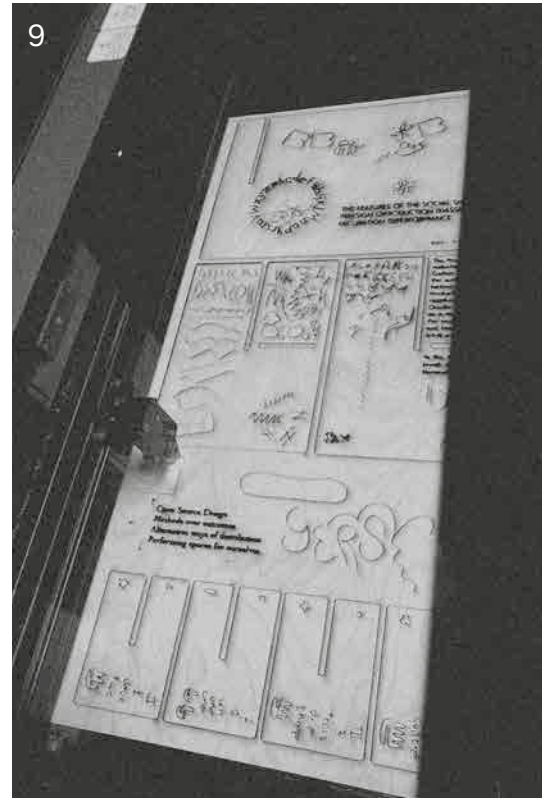

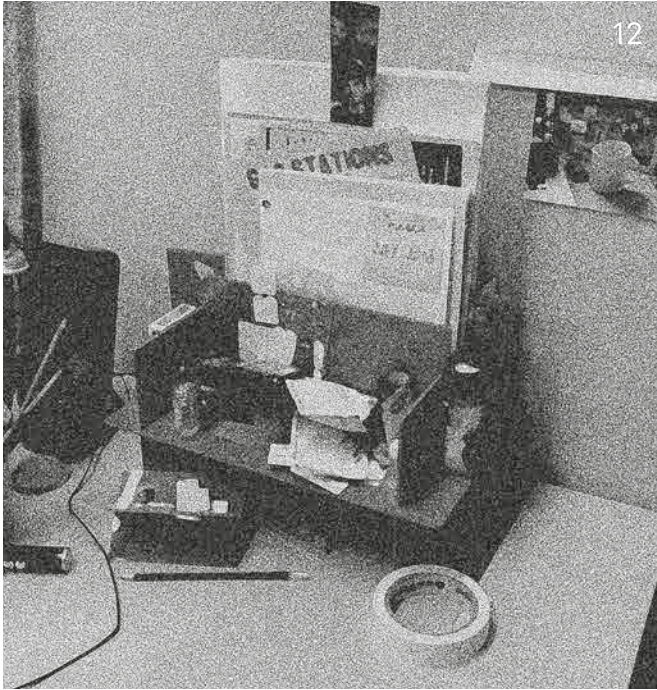

13

A BBUILDING BOOK

UBBB

three A3 pages
to fill in,
scan, vectorise
and lasercut!

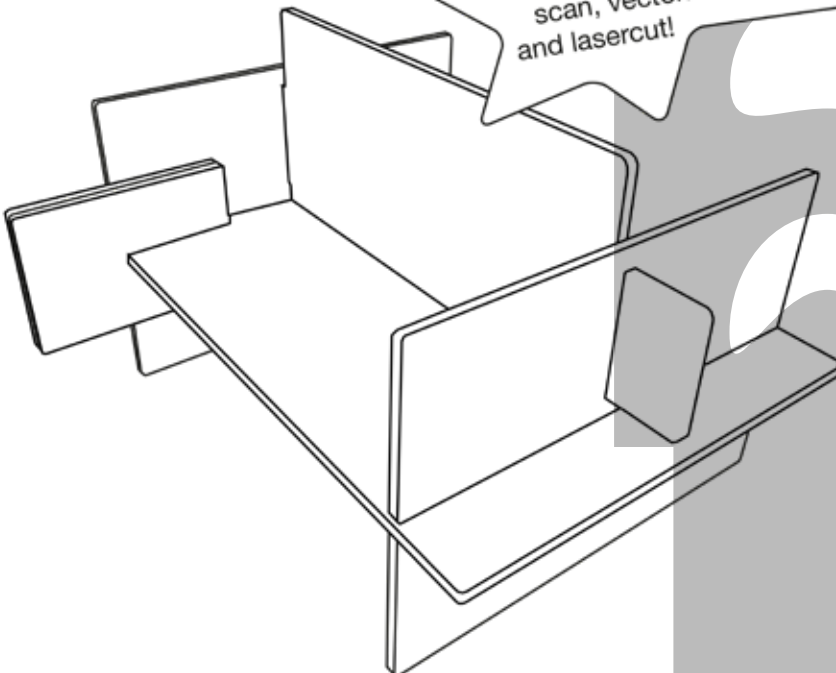

B.B. WOP

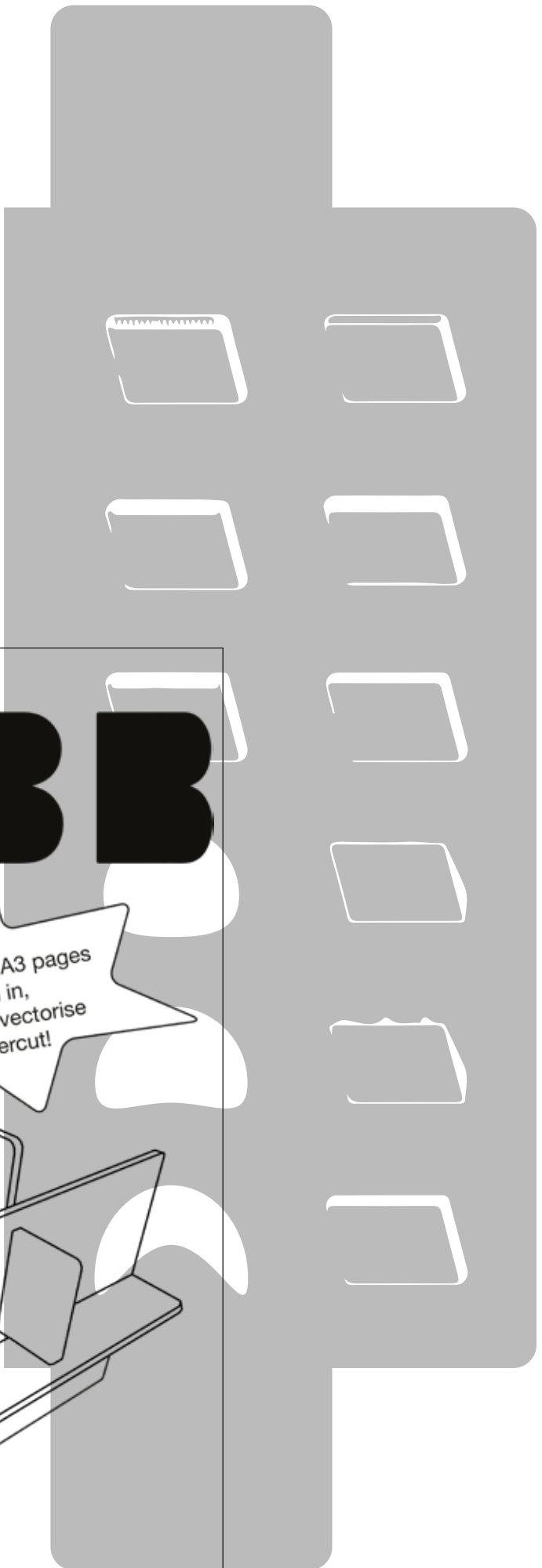

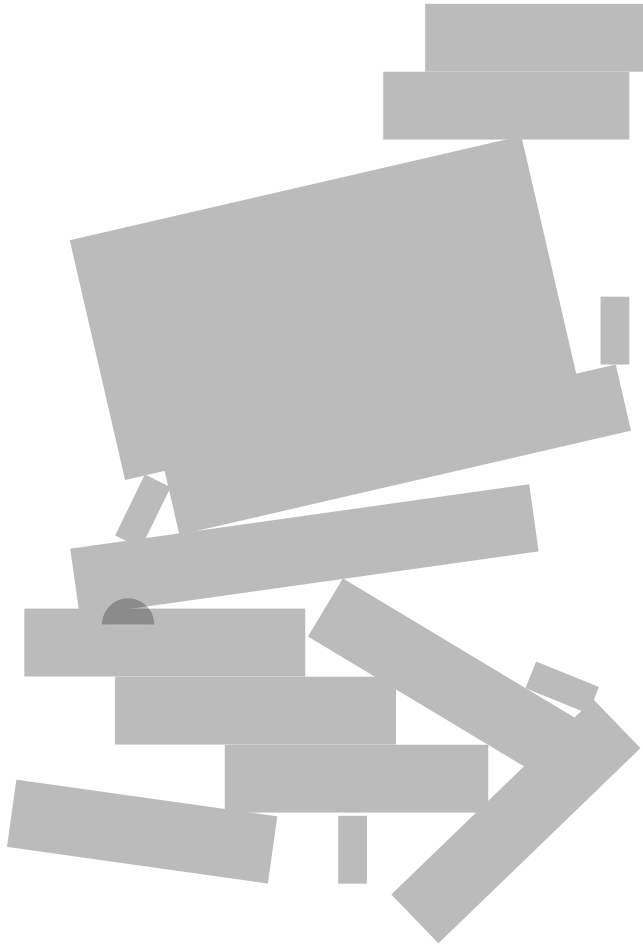

A stackable kind ↑ ↑

Location: Amsterdam
Name: V. Osox
Publication date: 20.02.2023



In December of 2022, I was invited to participate in the first assembly of a new squat in Amsterdam. This moment gathered numerous individuals part of different social, political and/or activist backgrounds, organisations and institutions. Core members of the collective laid out their aims and principles, inviting everyone present to engage in the conversation and participate to the construction of this new space.

A reoccurring subject at the meetings had been to create a welcoming spot for people to hang out, drink coffee or an office, in which books and computers could be made available. A big box full of books was thus still waiting to be put in the open.

Shelves were needed! The opportunity thus presented itself for my contribution to the making of the space.

Together with a friend of mine, A (a fellow conceiver of objects who also visited the space on several occasion) we decided to build a pair of shelves. Two at first, enough to host the books in the big box, but design in a way that could easily accommodate growth as the number of books on display would increase.

We decided to make a modular kind of shelf that would be easy to reproduce. It also had to be something we could build in the space itself using the tools and materials already available on the spot. These restrictions were necessary for several reasons. Anyone eager to grow the shelving structure should be able to understand how the shelves were made at a glance.

The same tools and materials we used must always be available in the space itself, as to avoid waste in time and energy to gather tools difficult to access. The shelves needed to adapt and move quickly and independently from us being there, considering that squatted spaces are often defined by urgency and uncertainty.



Following the space's ongoing activities and changes on- and off-line we noticed that the space had no fixed floorpan yet. And maybe would never have one. The capacity to host events and gatherings of all sorts in the communal spaces is indispensable to the space's aims. Because of this constant flow of events and gatherings, the space is in need of a versatile object that would not get in the way of its impermanent configuration.

While looking into potential portable and publication-friendly formats, I came across moving boxes dimensions (45cm x 47cm x 51cm). Flipped on the side they were close to most required shelving dimensions. So we came up with a design based on standard moving box dimensions. Easy to transport, easy to stack.

At the beginning, we considered a structure based on a garden shed. Earlier on, the squat had humidity issues in the main communal space. A number of posters and zines in half of the room had already curled up. With this in mind, I thought the shelves should be made waterproof for the publications to stay in shape and easy to move around should other issues of that kind arise. By the time we got to the construction, that issue was resolved allowing us thus to drastically simplify our concept. Still, the box format seemed the most suitable, allowing the books to be both displayed and easily carried around. Also, keeping in mind that this space could be at this point still on the verge of eviction at any time (thankfully the space is still up and running today) the box format seemed perfect from all angles.

After that the design came together quite fast. A and I made a few sketches, we sat down together to discuss them and made a few changes. We made sure the lower pieces elevated the shelf a bit for a better grip, also keeping the publications away from direct contact with the floor. Finally, we removed some wood on the upper and lower surface, both to avoid turning the shelf into a closed box and to save up wood. V. Osox was born.

We did not go too much into material specifications for we weren't sure what type of wood would be available to us on the day. This flexibility proved beneficial on the spot. When assembling the shelves with A, we made two changes. First we added small off-cut pieces of wood found on the floor next to scrap wood to the upper slates of wood to add stability, then we realised an extra piece of wood was needed on both sides of the shelves to keep the smaller books from tipping over.

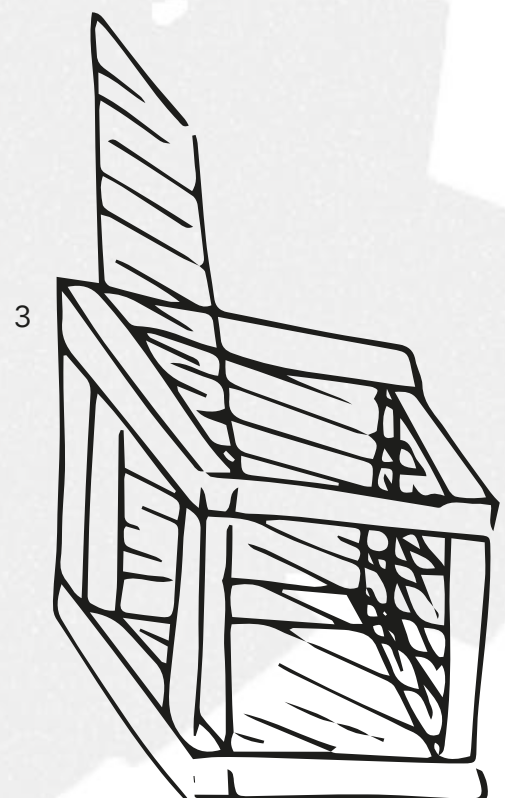
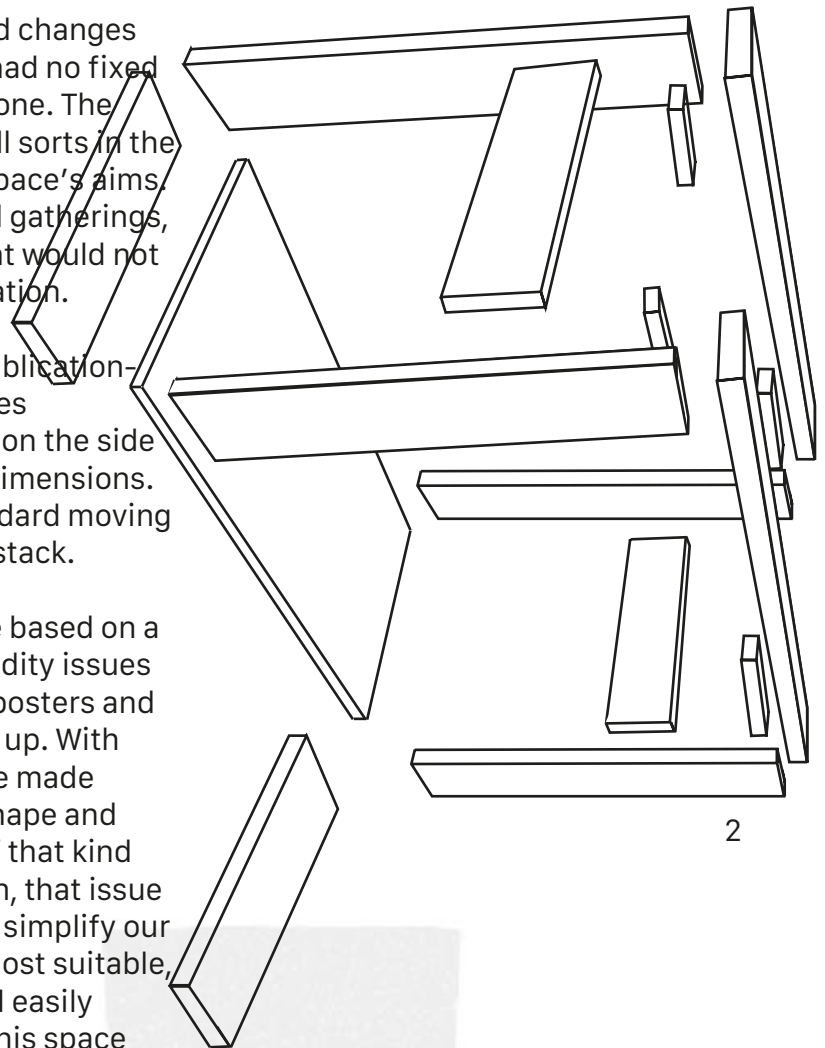

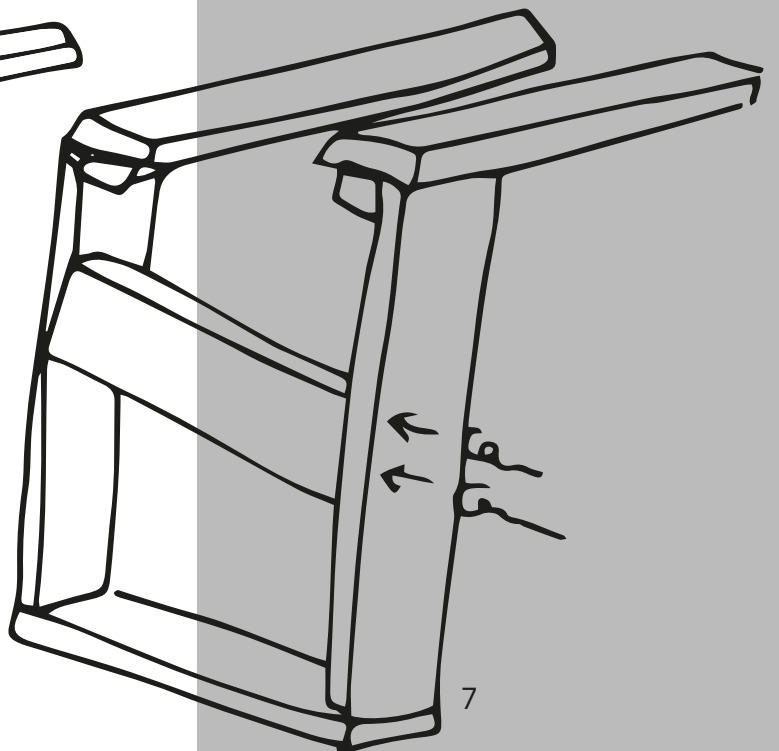
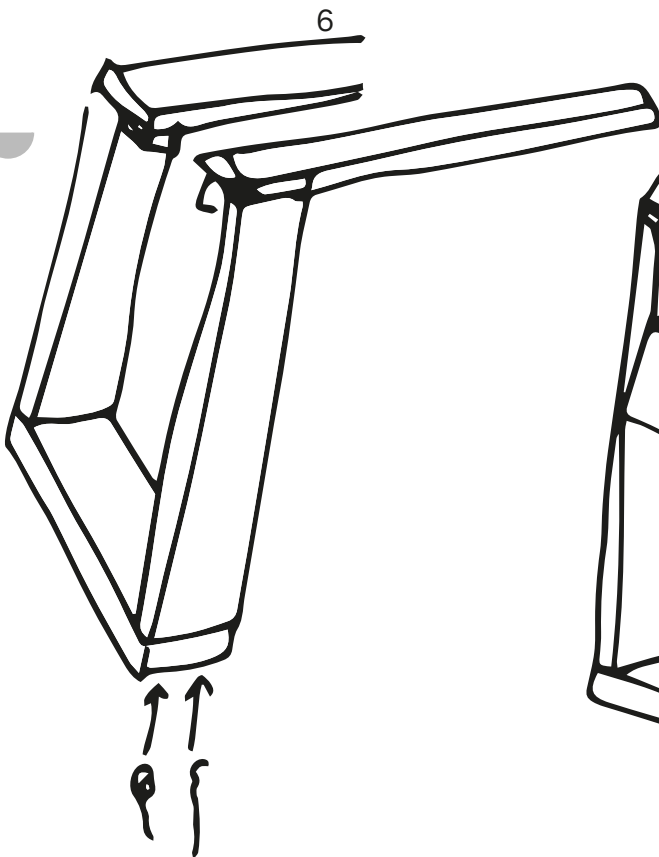
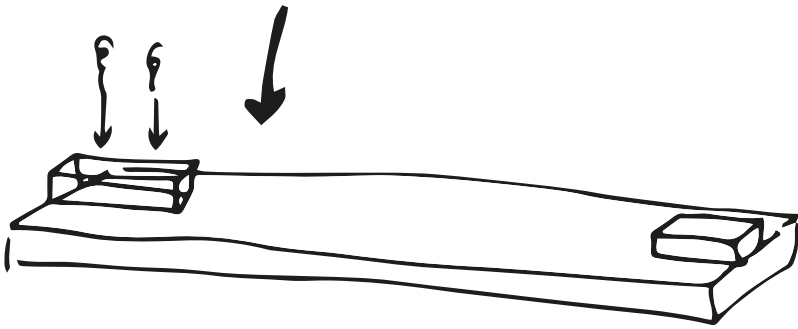
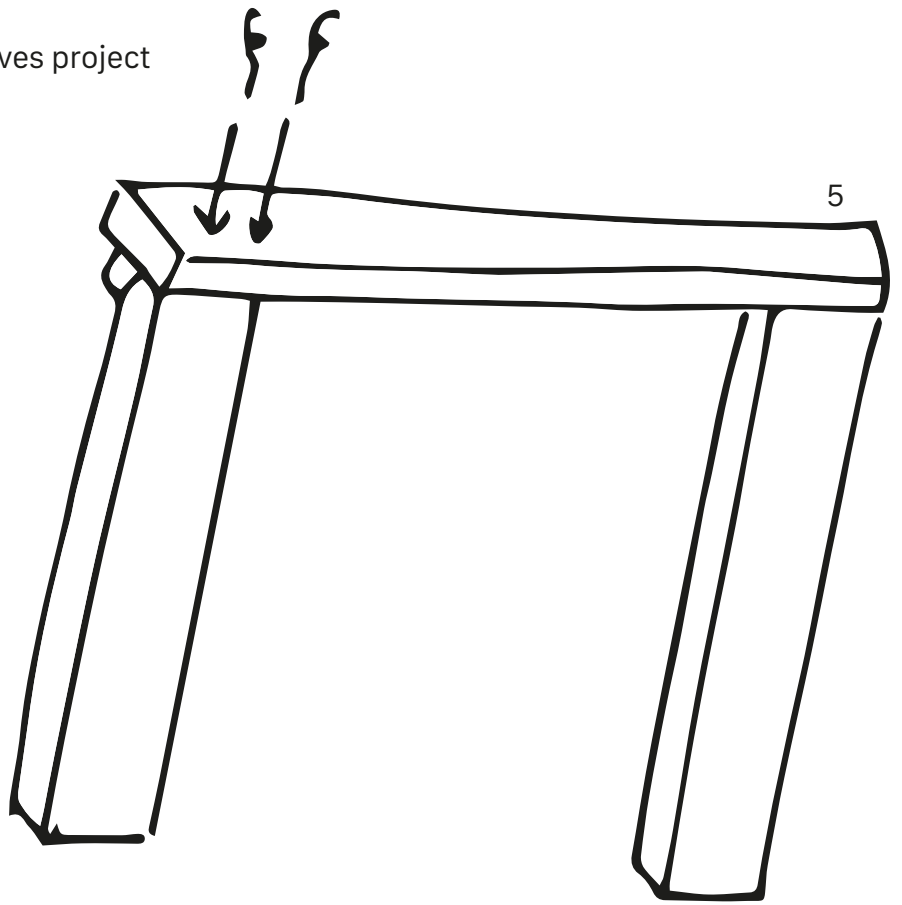
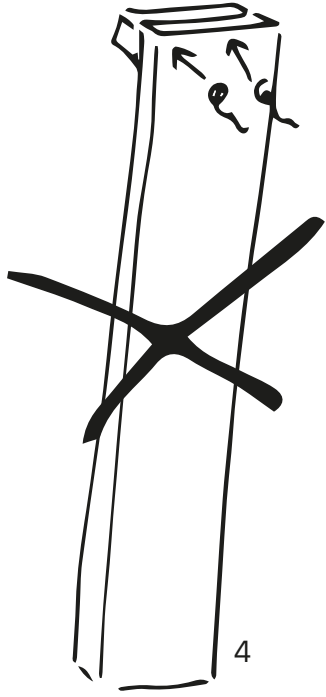

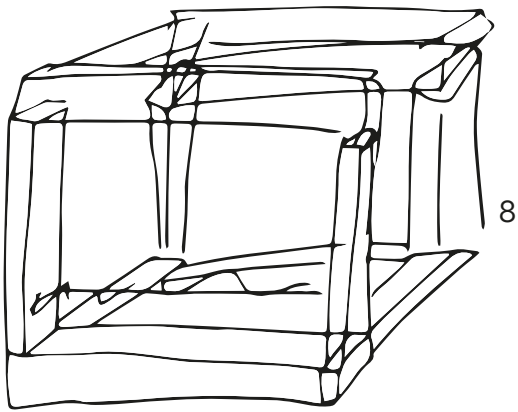

After a long day of work in the main communal space under coloured spotlights, two versions of V. Osox, were ready for use. We played around emptying the big box, all its books neatly fitting onto the shelves. While wondering where to leave the shelves, a member of the collective noted the versatility they offered in use, stackable yes, but also: put side by side, a plank could be added on top of them and bam: a bench!

